

FEATURES

- 700 MHz to 18 GHz
- Compensation for Temperature Drift
- Voltage Regulators for Improved Stability
- 12 Bit Tuning Resolution

DESCRIPTION

Micro Lambda *MLOM and MLXM Series* 1" Cube YIG Oscillators are available with integrated digital driver circuits. These drivers eliminate the need for customers to design or develop their own driver circuits and sophisticated test and alignment procedures. Integrating a driver at Micro Lambda's factory ensures peak performance. Alignment and compensation with the particular YIG oscillator can be maximized down to the component level.

All drivers in this series provide input voltage regulators and compensation circuits to improve frequency drift. All voltages required by the YIG oscillator, except the heater inputs are supplied by the voltage regulators.



COMMERCIAL DIGITAL DRIVERS

.7– 18 GHz YTOs, CD & CG SERIES

DRIVER INPUT & RESPONSE	SPECIFICATION (0 to + 65 deg. C)
Tuning Command	Start Word (all 0's) = Lowest Frequency Stop Word (all 1's) = Highest Frequency
Tuning Resolution	12 BIT Positive Logic (Fmax-Fmin)/4095 Bit Resolution All Data Bits have internal 10k ohm pull-up resistors to +5V
Frequency Accuracy (excluding hysteresis)	See Table
Tuning Speed (Note 1)	5 mSec for 1 GHz step to within +/-10 MHz. (residual FM is 10 kHz Pk-Pk)
Main Driver Inputs	
Supply Voltage & Current	+15 V +/- .5 V @ Oscillator Tuning Current +50 mA, Max. -15 V +/- .5 V @ 50 mA, (Plus Oscillator -5 Vdc Current if any) Max.
Supply Voltage Pushing	+/- 100 kHz, Max. @ +/- .5 Vdc
Supply Voltage Ripple	10 mV Ripple Pk-Pk over 2 kHz to 3 MHz
Ground	Chassis Ground
YIG Heater Voltage & Current	+24 Vdc ±4 Vdc @ 300 mA surge for 2 seconds, 25 mA steady state
Latch Enable	Polarity independent : ±12 Vdc or ±15 Vdc acceptable LATCHEN_N is a TTL, 5V CMOS control line. It has an internal 10k-ohm pull-up resistor to +5 V. It is used to transfer the data on the bus to the digital driver circuit. TTL high = data ignored. Connect to Ground if enable is not required. If the unit is to be used on a computer data bus, the below timing Diagram applies. (All times = Minimum) 10 nS rise/fall latch transitions.

Note 1. Optional 1 mS Tuning Speed Available.

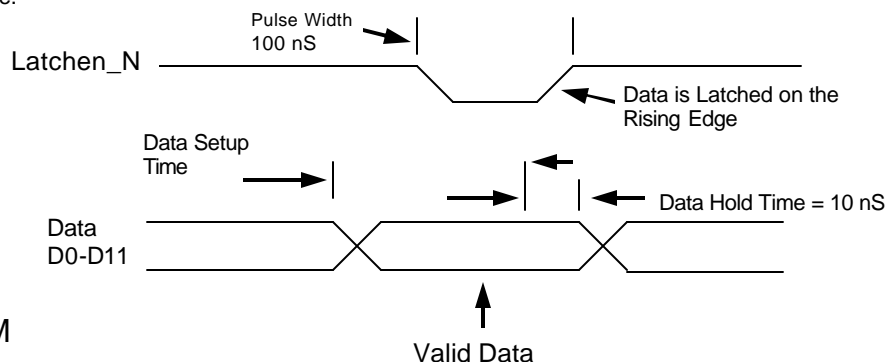

TIMING DIAGRAM

CD-SERIES — CONT.

FM Coil (CG Option)

Input Voltage	+/- 10V
Input Impedance	1 k Ohms
Sensitivity (Note 2)	+/- 2.5 MHz/V
Frequency Deviation	+/- 25 MHz

Note 2: FM Coil Sensitivity Adjustment Available. Sensitivity Stated is Average Over Frequency Range.

1.0" Cube YIG Oscillators with Positive Input Digital Drivers (0° C to +65° C)

Model Number	Frequency GHz	Accuracy (MHz) *	Current +15 V (mA)	Current -15 V (mA)	Outline Drawing	Outline Drawing (CG-Option)
Octave Bands						
MLOM-0102CD	1-2	+/- 3	200	50	11-105	11-110
MLOM-0204CD	2-4	+/- 6	300	50	11-105	11-110
MLOM-0408CD	4-8	+/- 8	500	50	11-105	11-110
MLOM-0812CD	8-12	+/- 12	700	50	11-105	11-110
MLOM-1218CD	12-18	+/- 14	1100	50	11-105	11-110
Multi-Octave Bands						
MLOM-0702CD	.7-2	+/- 3	200	50	11-105	11-110
MLOM-0704CD	.7-4	+/- 5	300	50	11-105	11-110
MLOM-0208CD	2-8	+/- 12	500	50	11-105	11-110
MLOM-0309CD	3-9	+/- 12	550	100	11-105	11-110
MLOM-0210CD	2-10	+/- 15	600	100	11-105	11-110
MLOM-0310CD	3-10	+/- 15	600	100	11-105	11-110
MLOM-0412CD	4-12	+/- 16	700	100	11-105	11-110
MLOM-0716CD	7-16	+/- 18	900	50	11-105	11-110
MLOM-0818CD	8-18	+/- 18	1100	50	11-105	11-110
MLXM-0818CD	8-18	+/- 18	1225	100	11-105	11-110

* Accuracy includes frequency drift and linearity errors over the temperature range.

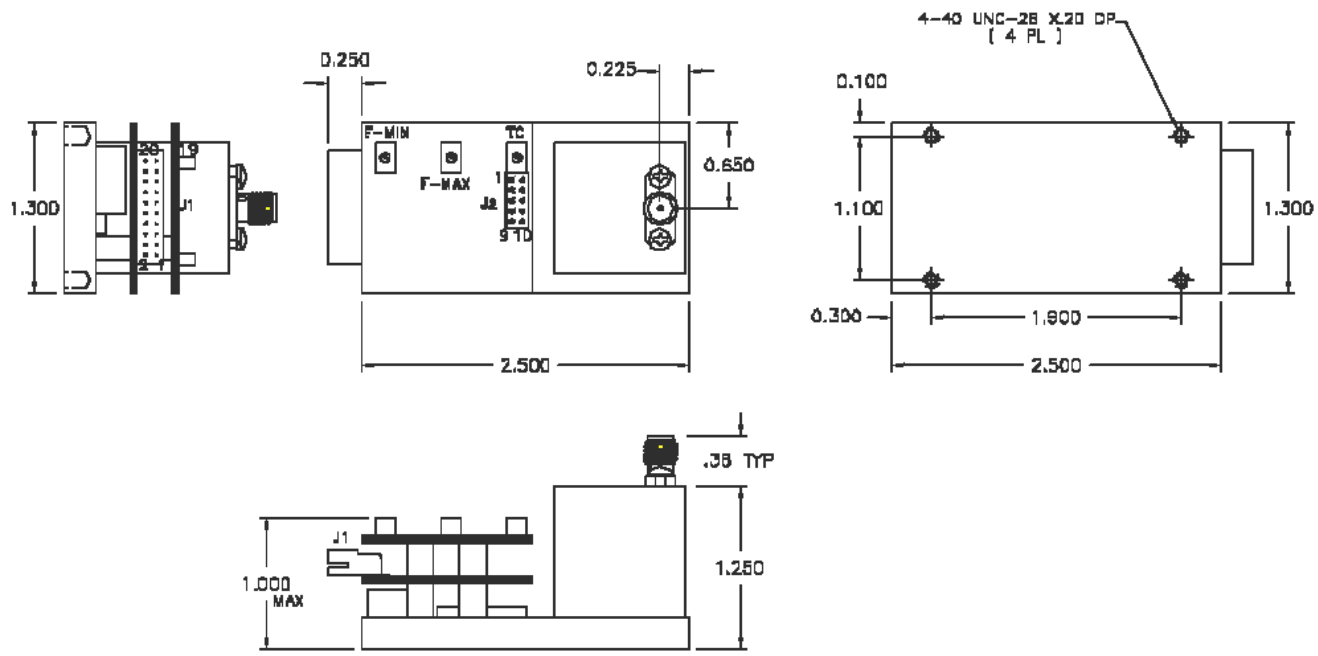

WEIGHT: 10 Oz

**BOTTOM BOARD (DAC BOARD)
J1 (2MM DUAL ROW TERMINAL STRIP)**

DIGIKEY PART # : H2069-ND
MATING WITH # : H2036-ND

**TOP BOARD (DRIVER BOARD)
J2 CONNECTION**

PIN	FUNCTIONS	PIN	FUNCTIONS
1	DATA BIT 0	11	DATA BIT 10
2	DATA BIT 1	12	DATA BIT 11
3	DATA BIT 2	13	LATCHEN_N
4	DATA BIT 3	14	GND
5	DATA BIT 4	15	SUPPLY +
6	DATA BIT 5	16	SUPPLY -
7	DATA BIT 6	17	HEATER +
8	DATA BIT 7	18	HEATER -
9	DATA BIT 8	19	FM + (*)
10	DATA BIT 9	20	FM - (*)

PIN	FUNCTIONS
1	TUNE +
2	TUNE -
3	FM + (*)
4	FM - (*)
5	OSC. VCC (*)
6	- 5V (*)
7	HEATER +
8	HEATER -
9	GND
10	N/C

- NOTES:**
- 1- (*) : NOT USED FOR FILTER
 - 2- RECOMMENDED WIRE SIZE = 20-22 GAUGE

UNLESS OTHERWISE SPECIFIED DIMENSIONS ARE IN INCHES TO DECIMALS ARE : FRACTIONS DECIMALS ANGLES = = =	CONTRACT NO.		 MICRO LAMBDA, INC.
	APPROVALS	DATE	
MATERIAL	DRAWN N.NGLIVEN	4/02/01	1" OSC. W/ 1.3" DIGITAL DRIVER (1.9 X 1.9 X 1.0")
FINISH	CHECKED	ISSUED	
DC NET SCALE DRAWING	SIZE	DATE No ORN63	DWS. NO. 11 - 105
			REV.

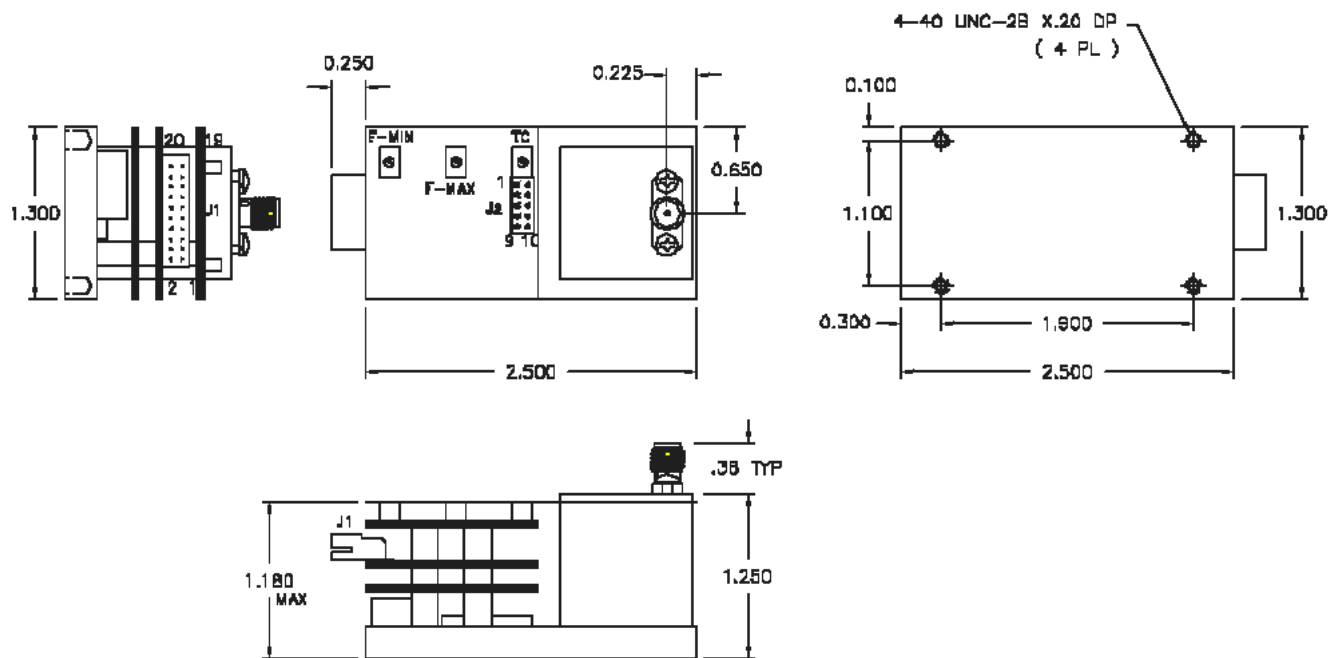

WEIGHT: 10 Oz

**BOTTOM BOARD (DAC BOARD)
J1 (2MM DUAL ROW TERMINAL STRIP)**

DIGIKEY PART # : H2089-ND
MATING WITH # : H2036-ND

PIN	FUNCTIONS	PIN	FUNCTIONS
1	DATA BIT 0	11	DATA BIT 10
2	DATA BIT 1	12	DATA BIT 11
3	DATA BIT 2	13	LATCHEN_N
4	DATA BIT 3	14	GND
5	DATA BIT 4	15	SUPPLY +
6	DATA BIT 5	16	SUPPLY -
7	DATA BIT 6	17	HEATER +
8	DATA BIT 7	18	HEATER -
9	DATA BIT 8	19	FM V-IN (± 10V) (*)
10	DATA BIT 9	20	FM RETURN (GND) (*)

NOTES:

- 1- (*) : NOT USED FOR FILTER
- 2- RECOMMENDED WIRE SIZE = 20-22 GAUGE

UNLESS OTHERWISE SPECIFIED DIMENSIONS ARE IN INCHES
TOLERANCES ARE :

FRACTIONS DECIMALS ANGLES
± .010 ± .005 ± .010

MATERIAL

FINISH

CONTRACT NO.

APPROVALS DATE

DRAWN N.NGLIYEN 11/29/01

DESIGNED

ISSUED



MICRO LAMBDA WIRELESS, INC.

1" OSC. W/ 1.3" DIGITAL & FM DRIVER (1.3 X 1.3 X 1.0")

SIZE

QAGE No
ORN63

DWG. NO.

11 - 110

REV.

DO NOT SCALE DRAWING