

FEATURES

- 500 MHz to 18 GHz
- Compensation for Temperature Drift
- Low-Profile Package
- Input Regulators for Improved Stability
 - Versus Power Supply Variations
- 12 Bit Tuning Resolution



DESCRIPTION

MICRO LAMBDA YIG Filters, model types MLFI Series and MLFM-series are available with integrated digital driver circuits.

MICRO LAMBDA drivers eliminate the need for customers to design or develop their own driver circuits and sophisticated test and alignment procedures. Integrating a driver at MICRO LAMBDA's factory ensures that peak performance will be achieved at the time of manufacture. Alignment and compensation with the particular YIG filter can be maximized down to the component level.

All drivers in this series provide input voltage regulators, and compensation circuits to improve frequency drift.

YIG drivers act as Digital Word-To-Current converters, converting standard 12 bit binary numbers into mA of current to tune a magnetic tuning coil.

POSITIVE INPUT DIGITAL DRIVERS CD Series

MICRO LAMBDA positive drivers are available for [commercial](#) environments. Standard products provide 12 bit TTL tuning input and operate over the 0° to 65° temperature range.

The CD series of digital drivers provide the main coil current from the +15 volt input line. Current increases linearly from 0 mA = 0 GHz at a rate of approximately 50 mA per 1 GHz. A 2-8 GHz filter will require 100 mA @ 2 GHz and 400 mA @ 8 GHz.

Frequency drift performance can be optimized with the inclusive temperature compensation circuits within the driver. This yields filter/driver combinations set at the factory with excellent frequency accuracy performance.

In special cases, speed-up circuits like those used to improve the tuning speed of YIG oscillators can also be included to provide both fast-tuned filters and with good accuracy. Filter parameters can be maximized during factory alignment to meet customer specific requirements.

AVAILABLE OPTIONS FOR CD-SERIES COMMERCIAL DIGITAL DRIVERS

- **Optional Tuning Speeds**



STANDARD POSITIVE INPUT DIGITAL DRIVER SELECTION GUIDE: CD SERIES

**YIG TUNED FILTERS WITH
COMMERCIAL DIGITAL DRIVERS**

.5 –18 GHz, CD SERIES

DRIVER INPUT & RESPONSE	SPECIFICATION (0 to + 65 deg. C)
Tuning Command	Start Word (all 0's) = Lowest Frequency Stop Word (all 1's) = Highest Frequency
Tuning Resolution	12 BIT Positive Logic (Fmax-Fmin)/4095 Bit Resolution All Data Bits have Internal 10k ohm Pull-up Resistor to +15V
Frequency Accuracy (excluding hysteresis)	See Table
Tuning Speed	5 mS for 1 GHz step to within +/- 10 MHz.
Main Driver Inputs	
Supply Voltage & Current	+15 V +/- .5 V @ Filter Tuning Current + 50 mA, Max. -15 V +/- .5 V @ 50 mA, Max.
Supply Voltage Pushing	+/- .5 Vdc , 0.1 MHz Max.
Supply Voltage Ripple	10 mV Ripple Pk-Pk from 2 kHz to 3 MHz
Ground	Chassis Ground
YIG Heater Voltage & Current	+24 Vdc ±4 Vdc @ 500 mA surge for 2 seconds, 150 mA steady state Polarity independent : ±12 Vdc or ±15 Vdc acceptable
Latch Enable	LATCHEN_N is a TTL, 5V CMOS control line. It has an internal 10k-ohm pull-up resistor to +5 V. It is used to transfer the data on the bus to the digital driver circuit. TTL high = data ignored. Connect to Ground if enable is not required. If the unit is to be used on a computer data bus, the below timing Diagram applies. (All times = Minimum) 10 nS rise/fall latch transitions.

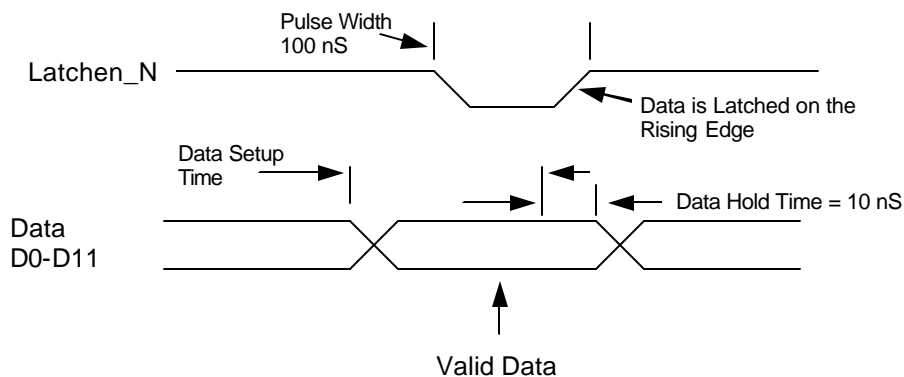

TIMING DIAGRAM



Bandpass Filters with Digital Drivers CD Series: Mini Profile Filter (0° C to +65° C)

MODEL NUMBER	# Stages	Frequency GHz	3 dB Bandwidth (MHz)	Accuracy (MHz) *	Current +15V (mA)	Current -15V (mA)	Outline Drawing
MLFI-41002CD	4	1.0 to 2.0	20	+/- 6	150	50	21-032-2
MLFI-42004CD	4	2.0 to 4.0	30	+/- 8	250	50	21-032-2
MLFI-44008CD	4	4.0 to 8.0	40	+/- 12	450	50	21-032-2
MLFI-42008CD	4	2.0 to 8.0	30	+/- 13	450	50	21-032-2
MLFI-61002CD	6	1.0 to 2.0	25	+/-6	150	50	21-032-2
MLFI-62004CD	6	2.0 to 4.0	40	+/- 8	250	50	21-032-2
MLFI-64008CD	6	4.0 to 8.0	45	+/- 12	450	50	21-032-2
MLFI-62008CD	6	2.0 to 8.0	40	+/- 13	450	50	21-032-2

* Accuracy includes frequency drift and linearity errors over the temperature range.

Bandpass Filters with Digital Drivers CD Series: 1" Cube Filter (0° C to +65° C)

MODEL NUMBER	# Stages	Frequency GHz	3 dB Bandwidth (MHz)	Accuracy (MHz) *	Current +15V (mA)	Current -15V (mA)	Outline Drawing
MLFM-30520CD	3	0.5 to 2.0	15	+/- 7	150	50	21-034
MLFM-40540CD	4	0.5 to 4.0	15	+/- 10	250	50	21-034
MLFM-42008CD	4	2.0 to 8.0	30	+/- 13	450	50	21-034
MLFM-42018CD	4	2.0 to 18.0	30	+/- 13	950	50	21-034
MLFM-46018CD	4	6.0 to 18.0	40	+/- 13	950	50	21-034

* Accuracy includes frequency drift and linearity errors over the temperature range.

Outline Drawing: 21-032-2

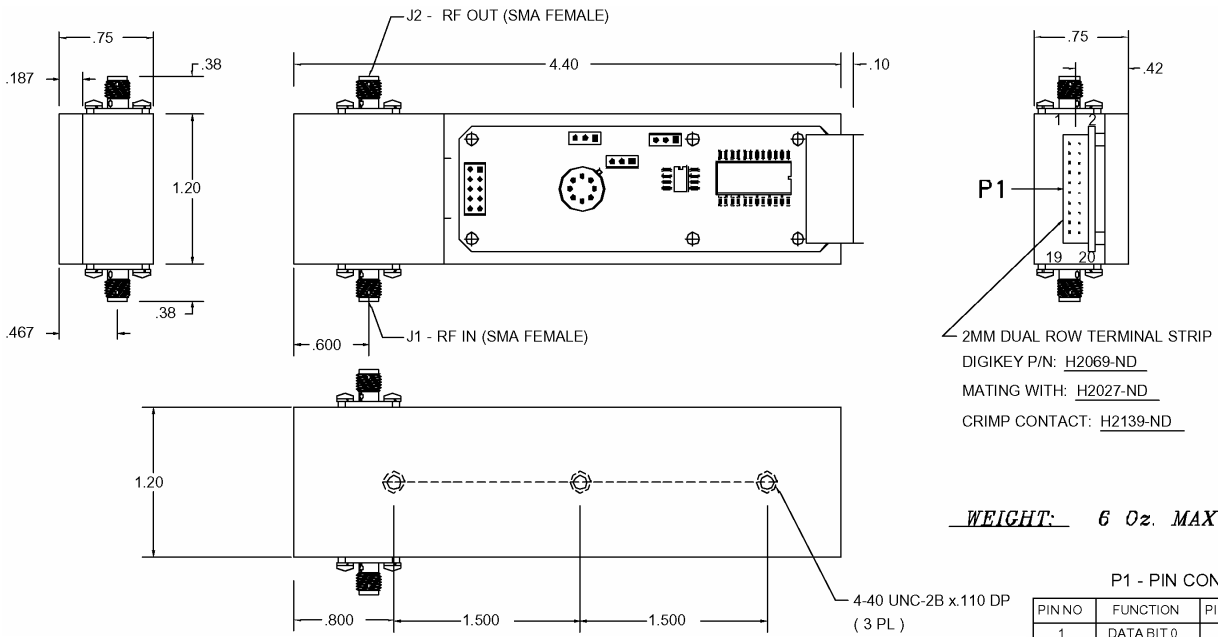

* POWER SUPPLY & GROUND WIRES=22-24 AWG
 DATA 000= F-MIN LATCH_EN 0 = DATA ACTIVE * OTHERS=24-26 AWG
 FFF= F-MAX 1 = DATA LATCHED * DIMENSIONS ARE IN INCHES

P1 - PIN CONNECTIONS

PIN NO	FUNCTION	PIN NO	FUNCTION
1	DATA BIT 0	11	DATA BIT 10
2	DATA BIT 1	12	DATA BIT 11(MSB)
3	DATA BIT 2	13	LATCHEN_N
4	DATA BIT 3	14	GND
5	DATA BIT 4	15	+ SUPPLY
6	DATA BIT 5	16	- SUPPLY
7	DATA BIT 6	17	HEATER
8	DATA BIT 7	18	HEATER RETURN
9	DATA BIT 8	19	N/C
10	DATA BIT 9	20	N/C

Outline Drawing: 21-034

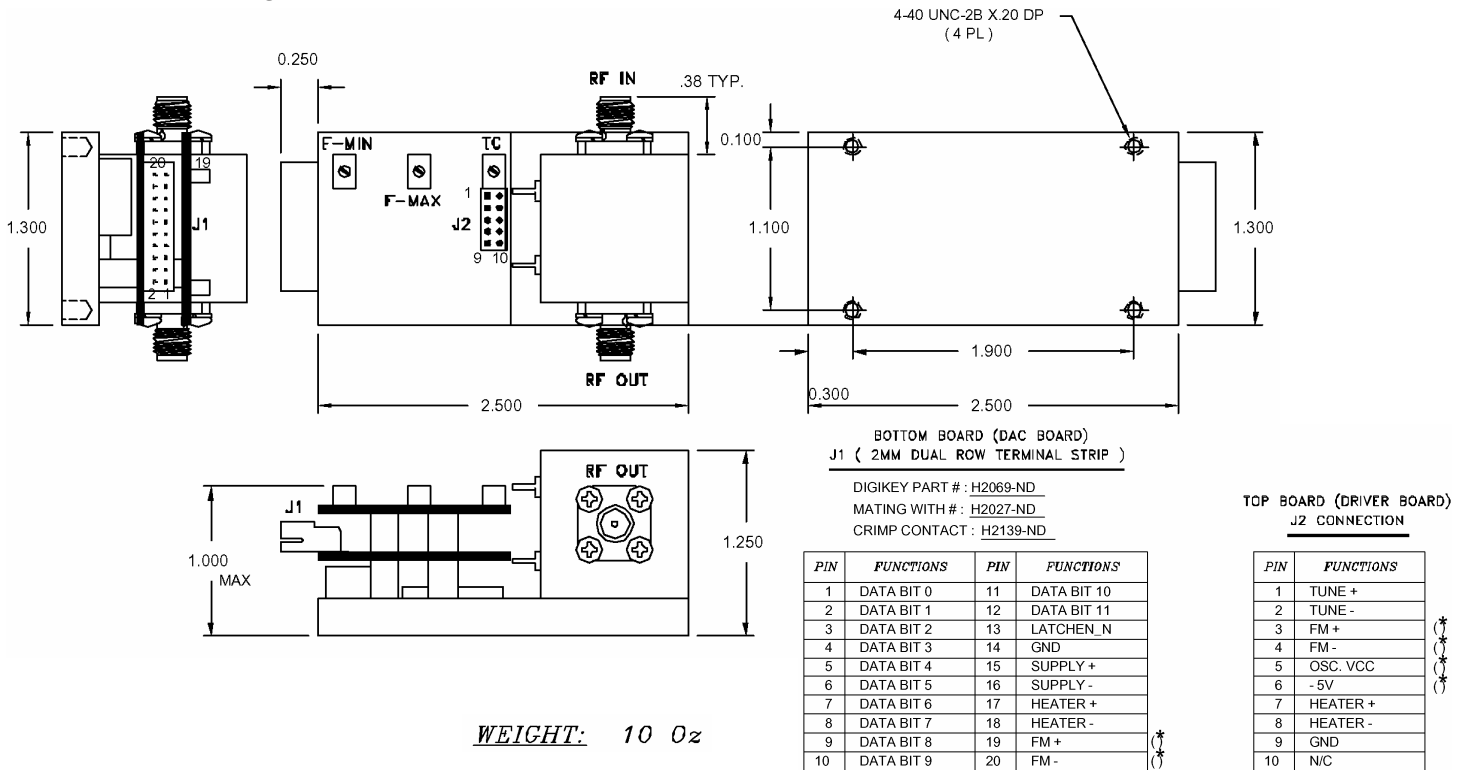

NOTES:
 1- (*) : NOT USED FOR FILTER
 2- RECOMMENDED WIRE SIZE = 20-22 GAUGE